

THIS DRAWING IS UNPUBLISHED. RELEASED FOR PUBLICATION
 (C) COPYRIGHT 19 BY AMP INCORPORATED. ALL RIGHTS RESERVED.

| LOC | DIST | REVISIONS | | | |
|-----|------|-------------|----------------------|------|-------|
| P | LTR | DESCRIPTION | DATE | DWN | APVD |
| DF | DO | H | REV PER 063D-0520-00 | 7-03 | CT DM |

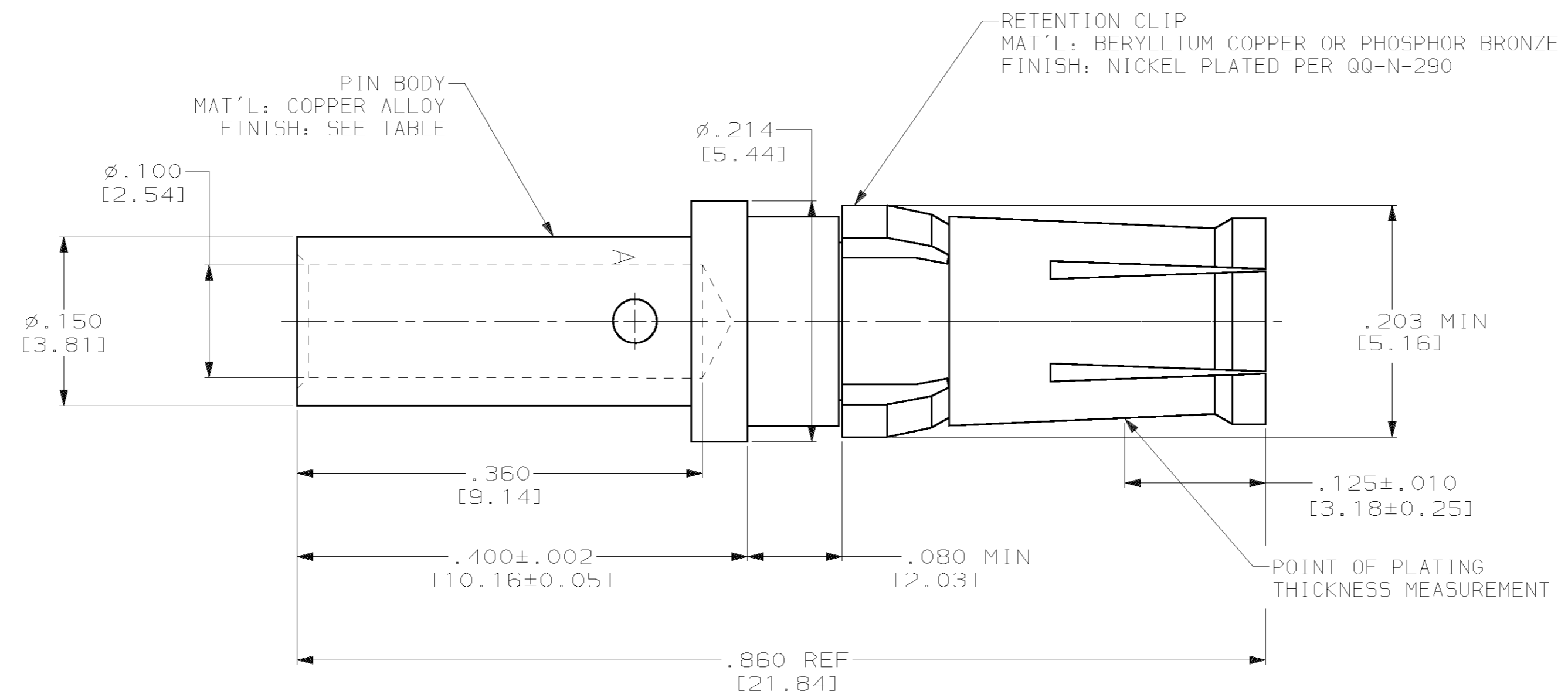

- THIS PART CONFORMS TO REQUIREMENTS FOR DANIELS CRIMP TOOL NO. M300-BT, WITH DANIELS POSITIONER PART NO. 5P689, STRIP LENGTH .375, SETTING #1.
- MATES WITH 212007-1 IN AMPLIMITE CONNECTOR ASSEMBLIES ONLY.
- FINISH: PLATED GOLD .000050 [0.00127] MIN THK PER MIL-G-45204 OVER NICKEL .000050 [0.00127] MIN THK PER QQ-N-290.
- FINISH: PLATED GOLD .000030 [0.00076] MIN THK PER MIL-G-45204 OVER NICKEL .000050 [0.00127] MIN THK PER QQ-N-290.
- WIRE BARREL WILL ACCEPT #12-#14 AWG WIRE.

| | | |
|---|--------|-------------|
| PRELIMINARY NOT RELEASED FOR PRODUCTION | 4 | 212008-2 |
| | 3 | 212008-1 |
| | FINISH | PART NUMBER |

| | | | | |
|--|--------------|------------------|--------------|----------|
| THIS DRAWING IS A CONTROLLED DOCUMENT. | | DWN | C.C. THOMAS | 11/10/00 |
| DIMENSIONS: INCHES [mm] | | CHK | D. MILLER | 11/10/00 |
| TOLERANCES UNLESS OTHERWISE SPECIFIED: | | APVD | D. MILLER | 11/10/00 |
| 0 PLC | ±- | PRODUCT SPEC | 108-10045 | |
| 1 PLC | ±- | APPLICATION SPEC | 114-10014 | |
| 2 PLC | ±- | WEIGHT | - | |
| 3 PLC | ±.005 [0.13] | CUSTOMER DRAWING | SCALE 10:1 | |
| 4 PLC | ±- | | SHEET 1 OF 1 | |
| ANGLES | ±- | | REV H | |
| FINISH | SEE TABLE | | | |

AMP AMP Incorporated
 Harrisburg, PA 17105-3608

ASSEMBLY, SOCKET CONTACT
 POWER VIII, #12 & #14 AWG